

Edward Jones FA assembly

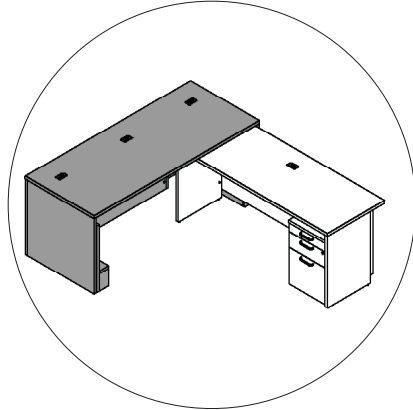



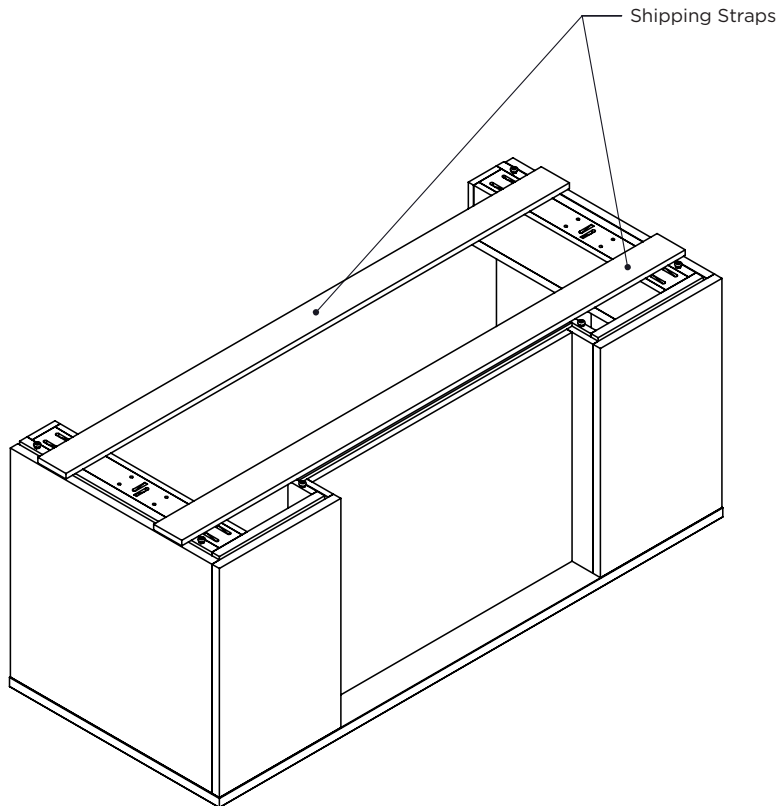
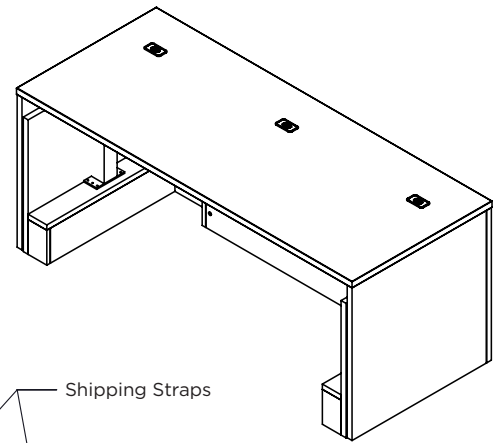

Desk Assembly

1. Unpack desk.
2. Place desk in desired location.
3. Remove the shipping straps once desk is in the desired location. They are located on the underside of the unit. They help the unit stay square during shipment and when moving the unit around in a building.
4. Set desk upright in its desired location.

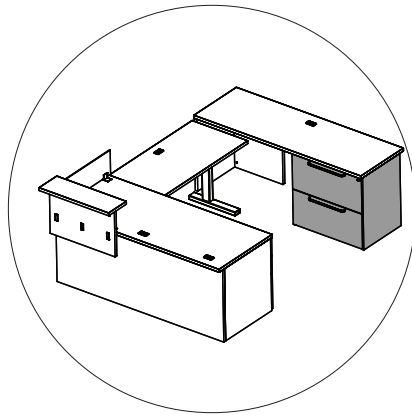



MATERIALS



HK-108
Mini-Fix Bolts

Return Assembly

1. Unpack return and assemble it to the desk as shown below.
2. Make sure all wires and cords are secured and not hanging below the worksurface.

